

Seat No.	
-------------	--

[5252]-502

S.E. (Civil) (First Semester) EXAMINATION, 2017

STRENGTH OF MATERIALS

(2015 PATTERN)

Time : Two Hours

Maximum Marks : 50

- N.B.** :— (i) Neat Diagrams should be drawn wherever necessary.
(ii) Figures to the right indicate full marks.
(iii) Use of electronic pocket calculator is allowed.
(iv) Assume suitable data if necessary.
(v) Solve 4 questions, Q. 1 or Q. 2, Q. 3 or Q. 4, Q. 5 or Q. 6, Q. 7 or Q. 8.

1. (a) Determine the maximum weight W that can be supported by two wires as shown in Fig. 1, if the stress in each wire is 120 N/mm^2 . [6]

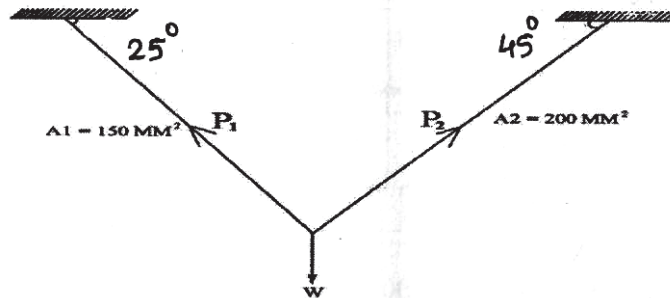

Fig. 1

P.T.O.

- (b) A beam of hollow rectangular section is subjected to a maximum shear force of 50kN. Find the maximum shear stress. Also draw the shear stress distribution across the section. Refer Fig. 1.2. [6]

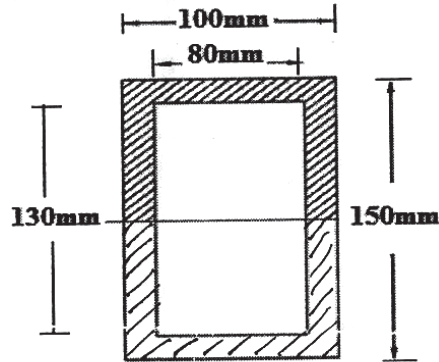

Fig. 2

Or

2. (a) A circular rod ABC is subjected to axial compressive load of 50 kN, the part AB is hollow circular with external diameter 25 mm & internal diameter of 10 mm & length of 200 mm. The part BC is solid circular with diameter of 25 mm & length 300 mm. Calculate total decrease in length of bar. Take $E = 200 \text{ kN/mm}^2$: [6]

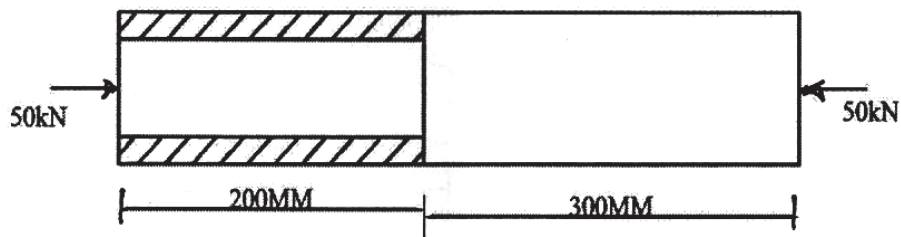

Fig. 3

- (b) The tension flange of cast iron I-Section beam is 240 mm wide & 50 mm deep. The compression flange is 100 mm wide & 20 mm deep whereas web is 300 mm \times 30 mm. Find the load per m run which can be carried over a 4 m span by a simply supported beam. If maximum permissible stresses is 24 MPa. (Fig.4) [6]

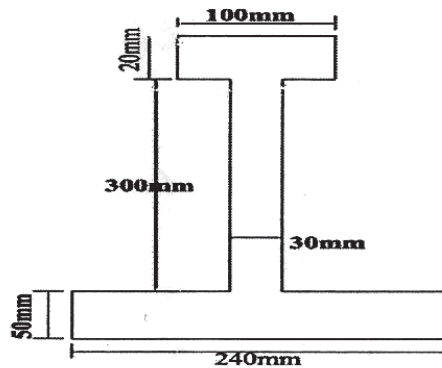

Fig. 4

3. (a) A hollow steel shaft transmits 200 kW of power at 180 rpm. The total angle of twist in a length of 5 m of the shaft is 3° . Find the inner & outer diameter of the shaft if permissible shear is 60 MPa. Take $G = 80\text{GPa}$. [6]
- (b) The stresses at a point in a component are 100 MPa(T) & 50 MPa(C). Determine the magnitude of the normal & shear stresses on a plane inclined at an angle of 25° with tensile stress. Also determine magnitude of the maximum intensity of shear stress. [6]

Or

4. (a) (i) Write the assumption for finding out the shear stress in a circular shaft subjected to torsion. [3]
(ii) The circular shaft of 30 mm diameter is running at 85 rpm. If the shear stress is not to exceed 35 MPa. Find the power which can be transmitted by the shaft. [3]
(b) A bar 10 mm in diameter gets stretched by 0.3 mm under a gradually applied load of 800N. What stress will be induced in the same bar if the same load falls from 80 mm on a collar attached at the lower end of the bar ? Take $E = 200 \text{ GPa}$. [6]
5. (a) A simply supported beam loaded & supported as shown in figure. Draw SFD & BMD. Calculate maximum value of bending moment. (Fig. 5). [6]

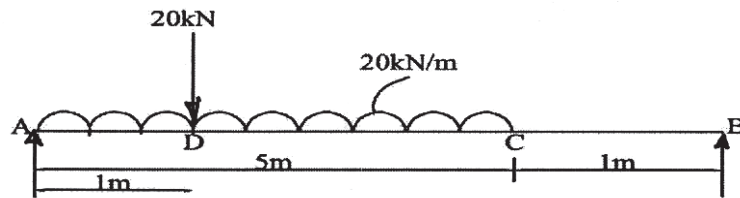

Fig. 5

- (b) The diagram shown in figure is the shear force diagram for a beam which rests on two supports. No couple is acting on a beam. Draw BMD & load diagram (Figure 6). [7]

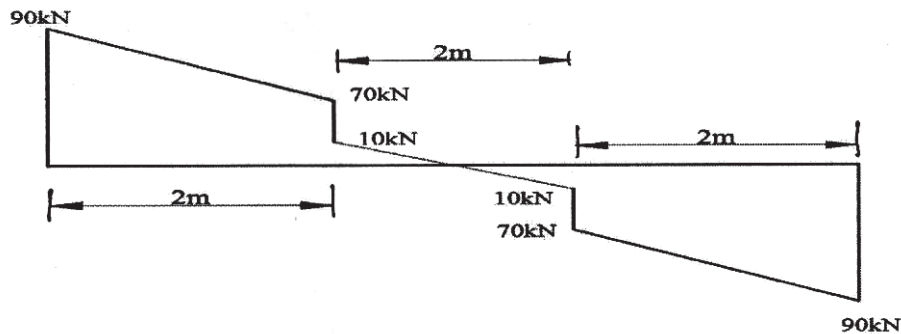

Fig. 6

Or

6. (a) Draw SFD & BMD for the simply supported beam as shown in fig. 7 [6]

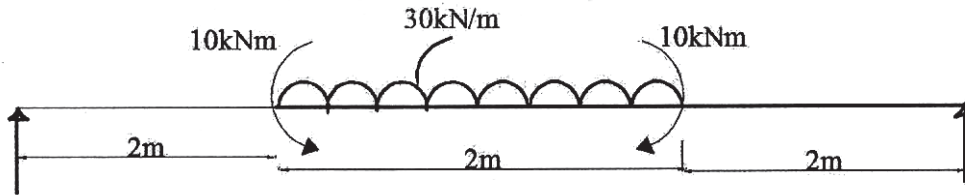

Fig. 7

- (b) The beam AD Simply supported at ends is having SFD as shown in fig. 8 Draw loading diagram. Hence plot BMD. [7]

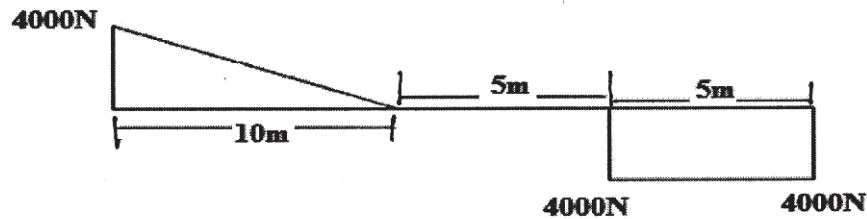

Fig. 8

7. (a) State the assumption made in Euler's theory & derive the expression for critical load for a column pinned at both its end. [6]
- (b) Compare the crippling loads given by Euler's & Rankine's formulae for a tabular steel strut 2.5 m long having outer & inner diameter as 40 mm & 30 mm respectively loaded through pin jointed at the ends. Take yield stress as 320 N/mm^2 , the Rankine's constant $= \frac{1}{7500}$ & $E = 2 \times 10^5 \text{ N/mm}^2$. [7]

Or

8. (a) A rectangular of width 140 mm & of thickness 120 mm carries a point load of 180 kN at an eccentricity of 10 mm. Determine the maximum & minimum stress at the base of column. [6]
- (b) An aluminum tube of length 8 m is used as a simply supported column with two ends hinged carrying 1.4 kN axial loads. If outer diameter is 50 mm. Compute the inner one that would provide factor of safety 2 against buckling. Use $E = 70 \text{ GPa}$ for aluminum. [7]